

The Patrol Leaders' Handbook



**This resource has been adapted
with permission from
The (U.K.) Scout Association's
The Patrol Leaders' Handbook.
Many thanks!**

Contents

The Patrol Leaders' Handbook

Chapter 1 — Getting Started5

(The Patrol Leader's Job)

The patrol system	Your Job
Court of Honour	You and your Scouter
How are patrols organized?	Setting the scene

Chapter 2 — Troop Night11

(Week by Week Responsibilities of a Patrol Leader)

Flag break	Helping new members
Keeping records	Select and read troop prayers
The patrol meeting	Investiture
Helping to run troop games	Other responsibilities

Chapter 3 — You And Your Patrol21

(Building Up a Patrol)

Choosing an assistant patrol leader	Sharing leadership
Your first meeting	An approach to starting a patrol
Developing your patrol	Handling individual problems
Handling your patrol	

Chapter 4 — The Court of Honour29

(Decision-Making in the Troop)

What is a Court of Honour?	What records are kept?
Who comes?	Who is the Court of Honour responsible to?
What does it do?	What's in it for me?
How often does it meet?	Can the Court of Honour do anything just for itself?
Where does it meet?	
Who does what?	

Chapter 5 — Getting the Job Done!37

(Training Other Scouts)

Helping your patrol learn	How people learn
Decide what needs doing	Putting training into practice
Agree on an activity	Looking back (evaluating)
Planning	Example training plans

Chapter 6 — Patrol Activities45

(Things to Consider When Planning Patrol Events)

- Choosing activities
- Safety
- Permission
- Equipment
- Ideas
- Adventurous activities
- Ready-to-use ideas
- Just for fun
- What other ideas can you think up?

Chapter 7 — Camping61

(Step by Step Guide for Organising a Patrol Camp)

- Types of Patrol camp
- Organizing a camp
- Camp programs
- Menus
- Equipment
- Transportation
- Cost
- Getting permission
- On your return

Chapter 8 — Personal File77

(Your Opportunities After You Leave the Troop)

- Where next
- Using your experiences
- Your progress within Scouting
- The next Scouting step — Venturers

Chapter 1

Getting Started

Congratulations on becoming a patrol leader!

In this book we've brought together ideas which will make *your* job easier. It will also give you information about various tasks which you will have to tackle.

It gives you details of the patrol system and the Court of Honour, plus ideas for patrol camps and activities.

Finally, there is help with your own personal development. Use the book as your own personal guide.

So let's start at the very beginning. What is being a patrol leader all about? Simply, it is a responsible role which gives you the chance to influence the troop you belong to and, in particular, the members of your patrol — a very important job.

You may be asking though...

“What do I have to do?”

“How do I do it?”

or even

“Can I do it?”

Well, don't worry — that's exactly what this book is all about.



The Patrol System

What is a patrol?



- A group of friends.
- A group where everybody is important.
- A group of four to eight people.
- A group which plans and does things together.

At the first trial Scout camp, in 1907 on Brownsea Island, Baden-Powell divided the 20 boys into four groups of five. He called them “Bulls”, “Wolves”, “Ravens”, and “Curlews.”

These groups became the first Scout patrols, and this system is one of the reasons for Scouting’s success over the years. Each patrol was led by a senior boy — a patrol leader! He was given full responsibility for the activities and behaviour of his patrol at all times. The patrol system was used for work and play.

This patrol system is still used today to divide members of a troop into small groups so everyone can play a part and be actively involved. Big groups of more than 20 usually break into smaller gatherings anyway; and by having smaller groups, everyone can have a say in what’s going on and be important to that group.

A patrol normally has four to eight members, of which one is the patrol leader and another is the assistant patrol leader. Other patrol members may act as quartermaster, secretary and treasurer.

Patrol leaders are trained so they can play a strong role running the troop with other patrol leaders in

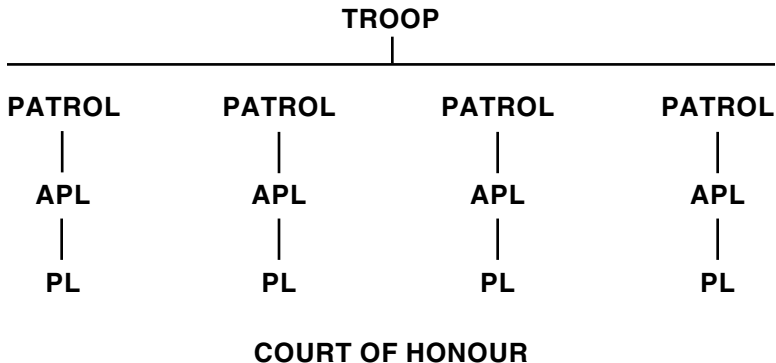

the Court of Honour. (More about the Court of Honour appears in Chapter 4.)

How are patrols organized?



The types of patrols differ from one troop to another. Here are some common ones.

- Patrols in which each patrol has a mixture of age and experience.
- Patrols in which Scouts of a similar age work together.
- A “new Scouts” patrol in which new members can get to know the troop before choosing which main patrol to join.



- A specialist patrol in which the members have a particular interest, such as air activities.

Some troops use other systems; there’s no single way to organize — it’s a case of which system suits your troop best. However, it is important that Scouts do have the chance to choose which patrol they want to be in and have the opportunity to move if they wish.

Your Job

As a patrol leader, you’ll be given responsibilities that you may not have experienced in the past.

You’ll be asked to lead your patrol and organize it so your patrol members progress and enjoy themselves.

You’ll need to seek the ideas and views of your patrol and take them to the Court of Honour to help plan what the troop is going to do. You will also have to keep your patrol informed about what is decided and why.

You’ll be asked to help members of your patrol through the different stages of the award scheme, and to teach some skills.

You’ll have to hear ideas, then help to make them happen so your patrol and the troop are active and involved.



Looking at these responsibilities, you will see that your new position means you'll need many skills and abilities you may not have needed before.

Your main tasks are:

1. To lead your patrol;
2. To help members make progress in the various awards;
3. To represent the views of your patrol;
4. To help run the troop with the Court of Honour.

*Who is there
to help?*



Don't panic! You'll get lots of support.

The picture shows the patrol leader as the trunk with the members of the patrol as the branches. The roots are the troop, the district, the region, Scouting at large and others who are there to support YOU, the patrol leader, in your job.

You and Your Scouter

Your first line of support will always be your Scouter. Having two leaders is not easy, but remember that even though you lead your patrol, your Scouter still leads the troop and has overall responsibility for the safety and welfare of all Scouts — including you — even when you are doing patrol activities. Getting the relationship right between you and your Scouter is very important, so try and build up a partnership between you.

Keep your Scouter in touch with what you are doing at all times. Scouters are trained to help you with problems that may arise, to know what the rules of Scouts Canada are, and how to organize things properly.

It's especially important to consult your Scouter before taking on any adventurous activity, but you will

also need to share your week by week plans.

Ask your leader for help with any difficulties which you might have in planning, discipline or thinking up ideas.

Other leaders in the group will be able to help you with equipment and ideas. Many districts and regions have specialists who are available to help your patrol and troop with adventurous activities such as rock climbing, canoeing, hiking, sailing, creative activities, and much more.

Outdoor skill courses and leadership courses such as patrol leader training courses are run by districts and councils.

Parents have skills, and many will be willing to share hobbies, skills and expertise with you at a patrol or troop meeting.



Your own Scout group will be able to help you with finances, transportation and advice.

Don't forget: these people won't be able to guess what support and help you need — you'll have to ask!

Setting the Scene

Being a leader is mainly about getting things done, but leaders are often remembered for how they act — not for what they say. Think about some leaders or even teachers at school that you know. Which ones do you like and respect? Which ones get the job done? How

do they act? What about the ones you dislike? How would you like to be seen as a leader, and how would you like to be seen by your fellow Scouts?

Perhaps with a friend or your other patrol leaders, you could chat about what sort of leader you would like to be. Make a plan to achieve this.

How you lead your patrol will change from situation to situation, but a patrol will follow good leadership and be unhappy with bad leadership.

Always remember that setting a good example is the best thing you can do.

Chapter 2

Troop Night

There are probably as many types of Scout troop nights as there are types of Scouts. Even so, your job as a patrol leader will be important whatever your situation. What sort of things might you be asked to do?

- Prepare the troop flag for breaking.
- Keep a register.
- Hold your own patrol meeting and pass on information to the Court of Honour.
- Represent your patrol at the Court of Honour meetings.
- Organize and run troop games.
- Look after new members of the troop.

- Present new Scouts for investiture.
- Organize patrol activities for part, or all, of the evening.
- Keep discipline in your patrol.
- Collect dues.
- Help train other Scouts.

Sounds like a lot? Well, you won't have to do them all every night! Let's look at them one at a time.

Flag Break

Many troop meetings start with breaking the flag. There aren't many ceremonies in Scouting, but it is important that those which we have are done properly. You can help the troop meeting get off to a

(The pictures below show how to fold a flag ready for breaking.)



good start by making the flag break smooth and efficient.

We have flag break to remind us that we have made a promise to do our duty to the Queen. This means that as Scouts we care about our country, and have a commitment to look after it.

At flag break...

- The troop should be standing at the alert.
- The patrol leader who is to break the flag steps forward and smartly pulls on the breaking rope.
- The patrol leader steps back and smartly salutes.
- Everyone else should salute at the same time.



At flag down...

- The troop should be standing at the alert.
- The Scout who is to bring down the flag steps forward and unravels the rope.
- The flag is then lowered slowly. It shouldn't touch the floor.
- Having lowered the flag, the Scout steps back and stands at the alert for a couple of seconds. No salute should be made at this stage.

Your troop might have a different way of breaking the flag from the one described here. However, whatever your tradition, it's important to do it smartly and correctly.

Keeping Records

You may be asked to keep records of your patrol. This might involve recording attendance of each patrol member at troop meetings, or each Scout's progress through the award scheme. Record keeping is only useful if it's reliable. If you're asked to look after any patrol or troop money, then you'll have to be very careful that you don't mix things up. You will have to show what has been taken in, what has been spent, and what you should have left over. Although it's your responsibility, you may want to appoint a patrol secretary and a patrol treasurer to do these two jobs.

The Patrol Meeting

Possibly your most important job is to represent other Scouts in your patrol. To do this properly, you must have a patrol meeting.

At the patrol meeting you have the chance to:

- Suggest ideas to your patrol.
- Make plans for your own patrol activities.
- Get ideas to pass on to the Court of Honour and your Scouter.
- Report back on previous Court of Honour meetings about what's happening.

When and where should you hold a patrol meeting? Sometimes you

might plan a few minutes into a troop meeting when you can get ideas from your patrol. You might meet at school, or somebody's house or perhaps while you're on a hike. There will be many other times. In fact, any time you're working together as a patrol you should be ready to listen to ideas for future activities.

Remember: The troop program is in your hands. Your patrol must understand that if they want to do exciting things, to make progress through the award scheme and have fun, they can make it all happen. If they don't get involved, they deserve what they get!

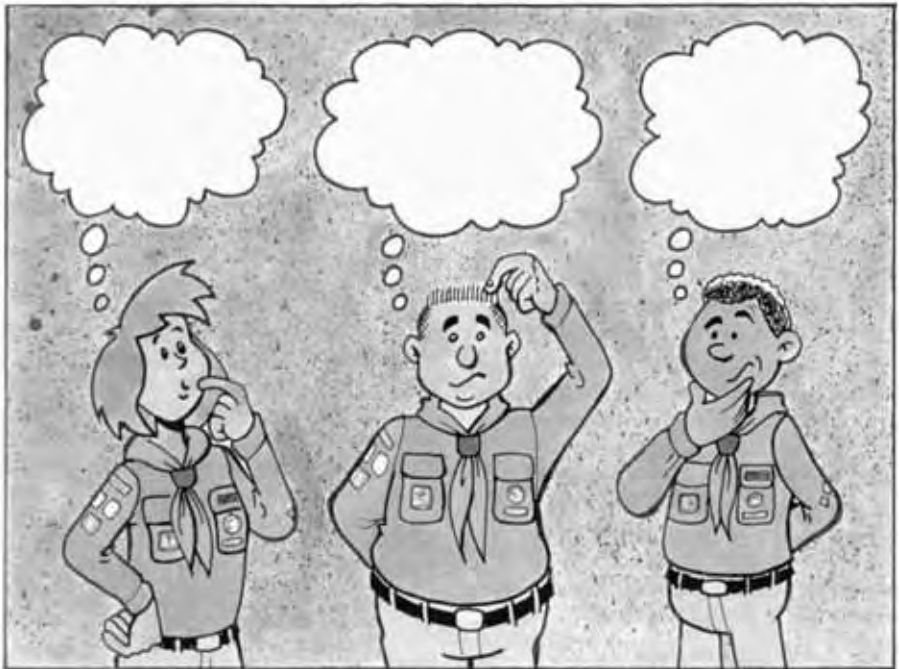

Six tips for running a successful patrol meeting.

1. Listen to other people's ideas.
2. Give everyone a chance to put their ideas forward.
3. Write down what is suggested.
4. Don't reject other people's ideas because you don't think they will work.
5. If an idea seems too ambitious, tell the patrol you will have to check with your Scouter.
6. Report back on what is happening, and put suggestions they have made into action.

“What happens if my patrol doesn't have any ideas?”

Try thinking up a few suggestions and asking your patrol to vote on each idea. Get each Scout in your patrol to think of their own favourite sports or hobbies. Could

any of them help the rest of your patrol to try the ideas themselves?

Use the award scheme to suggest ideas — each Scout looks through the requirements to see what he or she needs to do next. Look for matching activities, and pass on the choices to the Court of Honour.

“What happens if the ideas are too difficult for the patrol to put into action?”

Some ideas will be good, but you may not know how, or where, to start. You'll need to ask your Scouter's help. District and region advisors are also available to help you. Other patrol leaders may know what to do, or you could try asking your assistant district commissioner for Scouts. It may be better to do a particularly challenging activity as a joint patrol or troop activity.



“What if my patrol doesn’t want to discuss ideas?”

Sometimes you may find it difficult to get your patrol to sit down together and talk or be sensible. It’s best to find a time when nothing else is going on, or when they’re ready for a rest after another activity; otherwise the Scouts might be more interested in playing games. Sometimes you might find it easier to talk to members of your patrol one-on-one about their ideas.

Your patrol members will be more interested in contributing to patrol and troop planning once they see that their opinions *do* matter and *do* make a difference.

“How long should a patrol meeting last?”

If you decide to have a proper meeting, rather than just sharing ideas in your spare time, don’t allow it to go on too long. Ten minutes is ideal. After all, you want to get on with doing interesting things, not just talk about them!

“Why bother with patrol meetings at all?”

Everyone has a right to express his or her views about what activities the patrol or troop does. It’s “their” troop as much as it is “yours”; they should get what they want from it. To do this, everyone must have his or her say, so the Court of Honour can plan the best possible programs,

and makes sure everyone progresses in the award scheme through the activities decided upon. Scouting also tries to develop your ability to work with others and to co-operate together — an important skill for everyday life.

Helping to Run Troop Games

Everyone enjoys games in a troop night program. If you’re in charge of running the games, a few simple “rules” may guarantee success. If you haven’t planned what you’re going to do, games can quickly go wrong.

- Before announcing the game, make sure you have all the equipment ready.
- Don’t play the game for too long. It’s best to stop while everyone is still enjoying the game. If you play too long, boredom will set in.
- Choose games with rules that are simple to explain.
- Work together with your fellow patrol leaders and assistant patrol leaders. It’s easier to control other Scouts as a team, rather than by yourself.
- Take care to pick games which everyone can enjoy. Don’t end up pitting a small, young Scout against a 14-year-old giant.
- Make sure everyone is playing by the rules. If an individual decides not to follow the game properly, stop and remove the

Scout. You could ask another patrol leader to speak to him or her about correct attitude, or you may feel you need to pass on the problem to your Scouter. Whatever the case, your job is to get on with running the game with those who *do* want to play it properly.

- If a lot of Scouts start to break the rules and spoil the game, it's a sure sign that it's time to move on to something else!
- Choose inside games that won't damage walls or ceilings. Some games are too active to play indoors.
- Avoid using too many games which eliminate Scouts. It's great for the winner, but if you lose early on it's rather boring watching from the sidelines. Since younger, smaller Scouts are often the ones eliminated first, it can lead to boredom with the program.

Games

Here are a few troop games which you might like to try. None involve much equipment. For other ideas, check out Scouts Canada's book entitled, *Games... From A to Z*.

The Rope Circle

You'll need a thick rope long enough to be tied into a circle which all Scouts can hold onto. Tie the rope with a bowline knot to prevent it from slipping.

Get everyone to hold the rope and lean outwards. Spread the bigger Scouts out so they don't distort the circle. The rope should become tight. With care, everyone should be able to sit down together, then stand up again. As long as everyone works together, the rope will spread the load around the circle.

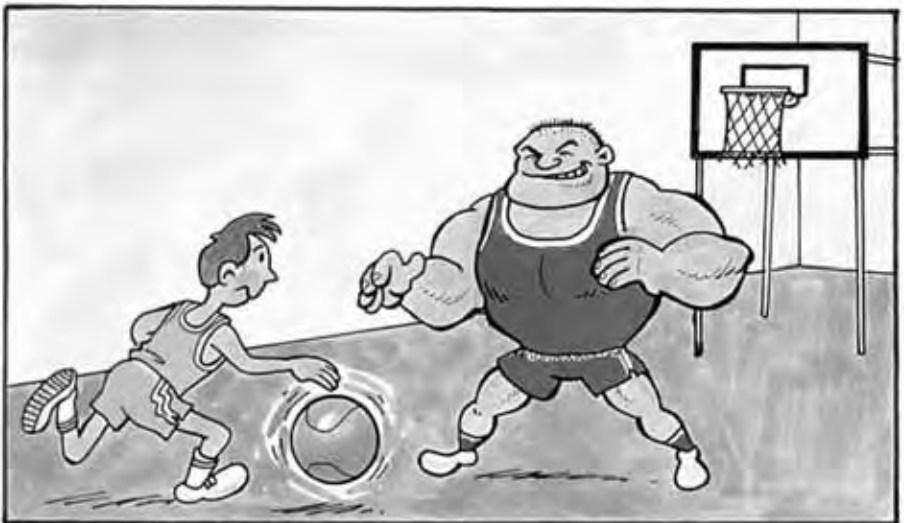



Quarter Volleyball

Divide your meeting place into quarters. Use chalk on the floor if you can, or ropes, benches or chairs. Divide the troop into four teams; each may only stay in their own quarters. Bat a light ball into the playing area. Scouts have to keep the ball out of their section by batting it upwards. If it touches the floor, blow a whistle and award that team a point. The aim is to avoid scoring points. Each time the ball hits the floor, players should return the ball to you; then, toss it back in to restart the game. This is a fast-flowing game, so be on your toes with the whistle. As a change, you can limit the amount of touches allowed in each quarter.

Kickball

Play this game outside on a field at least 100 metres long. There can be obstacles, including hills, or twists and turns. You need a ball

for each team, preferably one that can't be kicked a great distance. Play with two teams. On a signal, one member of each team kicks the ball forward. They step aside to let another team member kick it, and so on. The entire team follows the ball to the finish line, rotating kicks as often as is necessary to get to the finish line. The first team to kick the ball across the finish line, wins.

Blob

Two players join hands to form the "Blob." The Blob grows by chasing other players and touching them. (*Note:* Only the free hands at the end of the Blob can be used to touch players.) The Blob continues to grow until only one player is left untouched; that player is the winner.



Helping New Members

It can be pretty scary when a Scout first joins the troop. After all, new friends must be made, a new routine learned, and above all, most other Scouts will probably be bigger!

You can do a lot to help new Scouts settle in. Think back to when you first came to a troop night. What were you looking for? Most Scouts want to be accepted quickly, and to get involved.

“So, what can I do to help new Scouts?”

- Remember to explain the simple things: What do I do? Where do I stand at flag break? Who are the different people?
- Find out what interests new Scouts.
- Explain the rules of games and activities.
- Involve them in the patrol.
- Protect the new member from any form of bullying, including name-calling.
- Make sure the member has a *Scout Handbook*, and be sure to take a personal interest in helping them achieve their badges.
- Be the person’s friend.

You might also ask another member of the patrol (perhaps someone nearer to the new Scout’s own age) to help take care of them.

Select and Read Troop Prayers

Most troops have prayers at either the beginning or the end of meetings, or both. This helps Scouts with their Promise to “love and serve God.” If you’re choosing prayers, pick something relevant to that evening or that evening’s activity. For example, you might thank God:

- for the work of doctors and nurses after a first aid evening,
- for the fun you had with a particular activity.

Or you might ask for:

- help for a particular Scout who is ill,
- God to watch over your camp.

Prayers don’t have to be long or complicated. They can be simple



and in your own words. If you're asked to read a prayer, just read it in your natural voice. Speak up so everyone can hear, and speak a little slower than normal so that it's clear.

Remember: Troop members might not all be of the same faith. Be sure to check with a Scouter to ensure that your prayer is appropriate.

Investiture

At investiture, you have to present the new Scout to your Scouter.

At the beginning of the ceremony, you bring forward the new member, and both of you stand in front of your Scouter.

While the Scout makes the Promise, you remain beside the new Scout and everyone makes the Scout sign. After your Scouter has presented the troop, district and region badges, present the patrol badge and welcome the Scout into the troop. You then both go back to the rest of the patrol.

In this way you're able to give support to the new Scout whom you should already know quite well.

Take pride in how you welcome new Scouts to your troop. A settled, happy young Scout is a sure sign of a good, working patrol leader.

Other Responsibilities

Besides running patrol meetings and activities, as a patrol leader you'll also be working with Wolf Cubs. This will involve meeting new members before they join the troop, and possibly helping with Cub badges. Your Wolf Cub leader will be able to tell you what help is needed.

You may also be involved with the Venturer Executive Committee, arranging joint activities and events, and planning the progress of older Scouts to the company. The Venturer advisor and company president will be able to help your Court of Honour.

Two of your major responsibilities — training other Scouts, and being part of the Court of Honour — are featured in later chapters.

NOTES

Chapter 3

You and Your Patrol

The first few troop meetings with you in charge of your patrol will be very important. The Scouts will be keen to find out what sort of a patrol leader you're going to be. At the same time, you might be rather nervous, so let's get some help!

Choosing an Assistant Patrol Leader

Selecting a Scout who is going to help you as an assistant patrol leader can make a great difference to your job. Ideally you want someone who is a friend and who you see frequently. This will help you to become a "working pair," sharing patrol tasks. You'll find it much easier to plan, maintain discipline and think of ideas if you have a friend to rely on. So what is the job of the assistant patrol leader?

- To help the patrol leader run the patrol.

- To take the patrol leader's place in case of absence.
- To help the patrol leader motivate the patrol to tackle new and exciting projects.

Don't forget that assistant patrol leaders will want to be patrol leaders themselves one day, so give them a chance to get involved and "learn the ropes."

As a new patrol leader you might ask your Scouter and the Court of Honour to appoint the person of your choice as an **acting** assistant patrol leader at first. This way you can see how things go.

Your First Meeting

You will want to make a success of your first meeting so the Scouts in your patrol get the right messages. What is the 'right' message? It is...

- "This patrol leader knows the job."
- "We're going to get on well, and not waste time."
- "Coming to Scouts is fun."

- “We’re going to behave because the activities are great — no time for messing around.”

For your first meeting, make sure you’re on top of everything.

Choose something which you think you can do well so you feel confident. It may be a hobby or some Scouting skill which you enjoy and are good at.

Choose something quite simple. It’s important that everyone taking part sees the activity as successful. Check your idea with your Scouter; he or she might offer some suggestions or equipment.

Check the idea with your assistant patrol leader; use him or her to give you help and support. Plan how long the activity will take and how you will end the meeting. Finish while everyone is still enjoying it.

Get everything ready so you don’t waste time when your patrol is ready to go.

At the meeting...

Tackle the project enthusiastically! Quickly and efficiently, present what you want your patrol to do. Enthusiasm quickly spreads and will give your activity pace and interest. Involve all Scouts in the activity as quickly as possible.



After the meeting...

Chat it over with your assistant patrol leader. How did it go? What was good? What could have been better? What tips do you now have for next time?

Don’t forget that your Scouter is there to support you. Share your successes or, if things don’t go well at first, ask for advice and help.

A few successful meetings will quickly produce the feeling of value, fun and achievement.

Developing Your Patrol

Once you’ve established yourself, you’ll want to develop your patrol into a good working team.

When members take pride in their patrol, it's a good sign of a successful team.

The following games are designed to develop teamwork. You might find some of them useful in getting your patrol to work together as a team, rather than for themselves. Teamwork will develop slowly through everything you do together, but you can also help it grow.

The human pyramid

How quickly can you get the smallest patrol member to the top? Challenge other patrols.

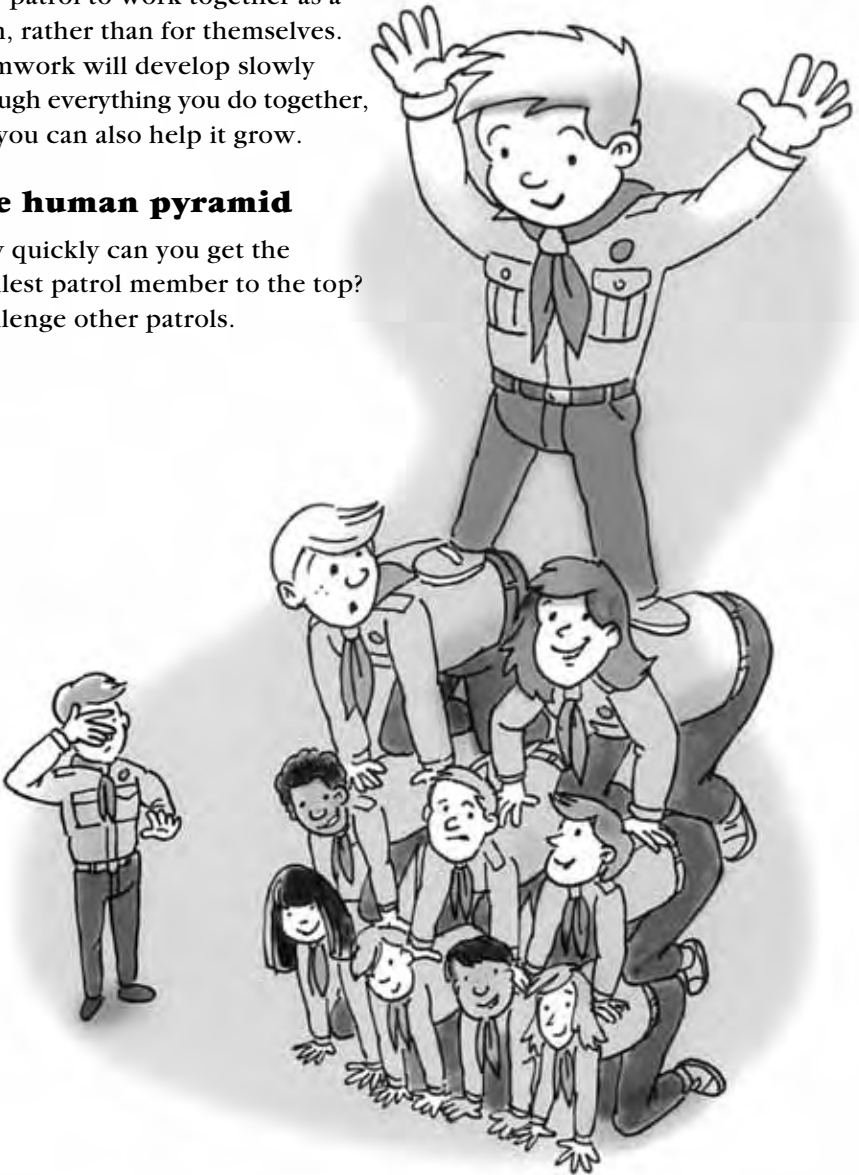



Blindfold tent pitching

One member of your patrol can see, but is not actually allowed to do anything except instruct everyone else. Other patrol members are blindfolded. Can you successfully pitch a patrol tent? Can you take it down again and pack it with somebody else in charge?

Lighting the candle

Your patrol is stuck on one side of a river (marked on the floor). They have to light a candle placed on the far side. You are provided with several garden canes, some string, matches and a match box. Can your patrol solve the problem?

Crossing the chasm

Provided with four chairs, can your patrol get themselves across the meeting room without anyone touching the floor? Challenge another patrol. Who can do it faster? Can you do it with fewer chairs?

Boil the water

Challenge another patrol to a competition to see which one can boil a measured amount of water on an open fire.

Stretcher race

Build a stretcher out of two staves and a jacket. How quickly can you carry one patrol member around an obstacle course?

Handling Your Patrol

A leader working with a team of people has three things which need to be considered:

The task:

Is the project being done successfully, or is it going wrong?

The group:

Is the patrol working together, or are members arguing?

The individual:

Is everyone taking part, or have some Scouts given up, dropped out or been left out?

You, as the patrol leader, have to make sure all these things are working properly. This means changing often to keep things going.

Sometimes you might have to **lead** the task by organizing everyone.

Sometimes you might have to **encourage**, keep up morale, and get the whole group working together well.

Sometimes you might let the patrol get on with the project and **help an individual** in the group who needs attention.

Sometimes you have to do all three things at once. That's why being a patrol leader isn't easy!



Sharing Leadership

Now that your patrol is working together and you have established your position, it's time to start to share the job: to share the leadership with others in the patrol (especially your assistant patrol leader), and to encourage and use other patrol members' ideas. In fact it's time to hold your first "patrol meeting."

For more information on patrol meetings, look back to Chapter 2.

An Approach to Starting a Patrol

Following is a step-by-step guide to some of the things we have been talking about. Remember it's only one approach, and each step may take more than one week.

Week 1:

Aim: Establish your position.

You and your assistant patrol leader organize a short activity for the patrol which you are confident about.

Week 2:

Aim: Build on your reputation.

Hold a short informal patrol meeting to write down names,



addresses and telephone numbers for each member, and to share any troop information. You and your assistant patrol leader may then organize another short activity for the patrol which you're confident will be a success.

Week 3:

Aim: Develop the patrol as a team.

Take part in some team-building games and challenges. Challenge other patrols to take part in an activity that you're good at.

Week 4:

Aim: Begin to get the patrol to share ideas.

Run the first full patrol meeting; decide on an activity for the following week. Take notes and pass major ideas to the Court of Honour.

Week 5:

Aim: Reinforce the idea of a patrol meeting.

Run the activity suggested at the previous patrol meeting. Hold a second patrol meeting and start looking for a larger-scale activity to plan. Share some of the planning jobs around the patrol. Report back to the Court of Honour.

Handling Individual Problems

When you're trying to get any group of people together, you will encounter some individuals who don't want to fit in. The result may be:

- Bad behaviour
- Opting out
- Lack of respect
- Bullying
- Arriving late to troop meetings
- Not turning up as expected.

So what can you do if you find a patrol member is giving problems?

There is no one single right answer since each situation is different. But here are some suggestions.

- Be positive. If the rest of the patrol is okay, the problem rests with the individual, not you. It's not your fault. In many cases the actual problem has little to do with Scouting.





- Try to figure out what is wrong. What do you think? What do others who you trust think about the difficulty?
- If you think you will get a sensible answer, ask the person privately and directly (1) what is the problem? and (2) what is the solution?
- Share the situation with other patrol leaders at the Court of Honour, and with your Scouter. They can then support you.
- Does the Scout feel he should have more responsibility? Can he plan/run an activity in the near future? Should he have a specific job?
- Is it a personality clash? Does he want to change patrols?
- Is the problem related to boredom? Would forming a new

patrol help? Could the person suggest and help organize new activities?

- If it's something about the patrol, can another patrol leader talk to the person about any problems and help sort them out?

Worrying achieves nothing. Find some support and look for ways to solve the problem.

Don't let one person's poor attitude spoil the development of the patrol. This is important! If a Scout continues to give you problems, don't be afraid to give the problem over to your Scouter. Your job is to run a patrol as well as you can, not sort out the troop's problems.

Chapter 4

The Court of Honour

This chapter describes your role as part of the Court of Honour.

As a patrol leader, you'll want to become an effective member of your troop's Court of Honour, and be fully involved in running your troop. It may have a well established Court of Honour already, with regular meetings; you may even have been to one in the past.

If not — don't panic

If your troop doesn't have a Court of Honour at the moment, this chapter will give some ideas so you can help start one. Watch out for small pointers called "hints for starters." These are specifically included to help you and other patrol leaders get going.

Whether you've been involved before, or whether it's all new to you, find out how it operates.

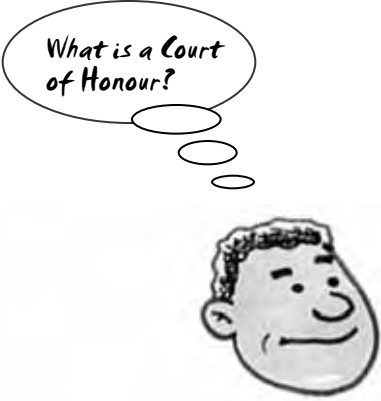

What is a Court of Honour?

Simple! It's a get-together of patrol leaders to talk about everything that happens in your Scout troop.



Who comes?

The Court of Honour decides who comes. Patrol leaders attend, as well as your Scouter (usually),

although this isn't absolutely necessary. The Court of Honour can invite anyone it wishes to a meeting; this might change from meeting to meeting. For example, you might invite:

- assistant patrol leaders,
- older Scouts,
- a Scout who has completed an award,
- assistant Scout leaders,
- the group Scout leader,
- the assistant district commissioner (Scouts),
- people who are helping the troop with training or an activity.

If the Court of Honour is to remain an effective group, don't let it get too big. A good size includes the patrol leaders, plus one or two others at any one time.

Hints for Starters

At your first meeting, get together with just the patrol leaders and your Scouter.

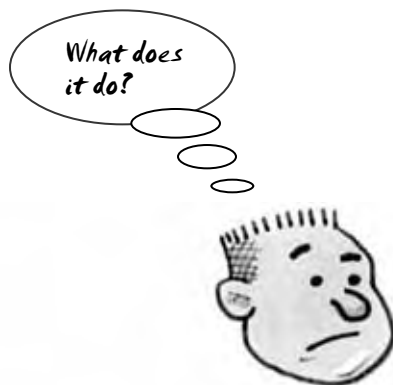

The Court of Honour meets to talk about what happens in the Scout troop and, therefore, plays a significant role in running the troop. Its discussion topics can be very wide and varied. It...

- helps plan the troop program,
- shares patrol activities and plans,
- discusses ideas from patrol meetings,
- maintains troop standards,
- looks after troop and patrol finances,
- discusses and approves appointments,
- checks progress of Scouts with their awards,
- invites guests,
- arranges outings.

Hints for Starters

Get together with just one other patrol leader — perhaps at school — and between you, write down a list of activities that you and your patrols like doing best. Take this list to the next Court of Honour.

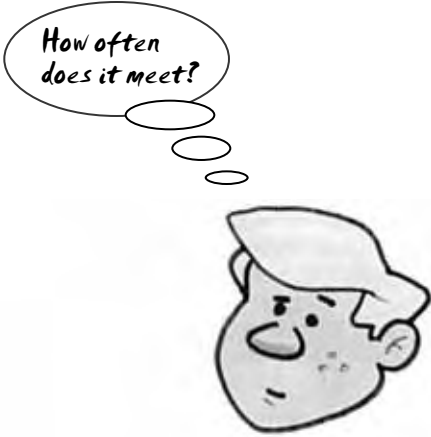

How often
does it meet?



Where does
it meet?

The Court of Honour will decide this, but six or eight times a year for formal meetings is standard for many groups. The number of meetings you need, and how long they last, will depend entirely on the amount of work to be done, and when it needs doing. You may not need a meeting for months and then need two or three meetings very close together when things get busy.

In addition to formal meetings, there are many other opportunities to discuss items. Take five minutes before or after the end of a troop meeting, late in the evening at camp, on a bus or in a car on the way to an activity.

Hints for Starters

At your first meeting, decide the dates of the next two or three meetings so everyone can plan to attend.

You'll decide where to hold your meetings. Anywhere is adequate, as long as you have enough space, and can talk in peace so you can achieve your goals. Here are some examples.

- Your sponsor's hall (perhaps there's a room set aside for committees or there's a corner somewhere that you could use).
- Either at a leader's house or one of the patrol leader's homes.
- In a park or campsite during the summer.

Hints for Starters

Ask your Scouter or an assistant Scout leader to lead your first meeting so you can learn how it's done.



Who does what?

There are quite a few jobs that need doing to make a Court of Honour work. Somebody needs to do the following tasks.

- Keep control of the meetings.
- Control the discussions.
- Ensure that they stick to the point.
- Ensure decisions are made.
- Ensure everyone has a “say.”

The person who does all of these tasks is called “the chair.” It’s a good job for one of the senior patrol leaders.

If the Court of Honour has any special funds, deals with subscriptions, or handles any other money, someone will need to look after it. This person is called a “treasurer.”

Before the meeting, someone has to write a list of the things to be discussed. At the meeting this person will record what has gone on, list the decisions made, along with the action to be taken, and by whom. This person is called the “secretary.”

As a patrol leader, you will probably take on one of these jobs at some time. Each of these jobs needs different skills and practice. If you’re setting up a new Court of Honour, perhaps you could take turns as the secretary, or chair the meetings until one person feels confident to do it more permanently. Your group committee has people who do these jobs so why not ask them to show you what to do.

If you have a special skill (such as being good with money and accounts), why not offer to do the job your skills suit.

Hints for Starters

Why not see if you can visit a meeting of your Venturer company’s Executive Committee? You can watch how they run their meeting.



What records are kept?

For formal meetings, everyone tells the secretary before the meeting what they want to discuss. The secretary then produces an agenda.

A sample agenda may look like this:

3rd Weston Park Scout Troop
Court of Honour meeting
to be held on Tuesday
8th January at Dick's home,
43 Hoy Street at 7:00 p.m.

1. Minutes of last meeting.
2. Matters arising from the Minutes.
3. Review of recent events.
4. Future troop programs.
5. Future patrol activities.
6. Summer camp.
7. Treasurer's report.
8. Scouter's notices.
9. Any other business.

Your agenda doesn't have to be as formal as this one, but it must clearly show everyone what will be discussed.

The agenda can be written at the beginning of the meeting, but it's helpful if it's ready in advance so everyone knows what items are coming up, and can discuss them at a patrol meeting.

Whoever chairs the meeting reads through the items. The secretary records important details of the meeting. These notes are called "Minutes" and are the official record of what happened at the Court of Honour. They don't need to be long, wordy documents, just a simple list of decisions made, describing who is doing what.

Hints for Starters

The agenda for your first meeting could include:

- where and when to meet,
- who attends,
- agenda for the next meeting.

The secretary makes sure everyone has a copy of the Minutes after the meeting, so members know what they have to do.

If you have access to a computer and printer, use these. The secretary should keep a copy of all Minutes in a book or a file for future reference.

Hints for Starters

If you do your Minutes on computer, you can easily print off the number of copies you require. If you don't have a computer, just photocopy them at a library. E-mail is also an effective way to distribute Minutes.

The Court of Honour will also have to ensure that everyone's award progress is recorded if the troop uses a central system. The court



should also record past programs so it will be able to plan future programming. Different Court of Honour members can take on different secretarial tasks.

Who is the Court of Honour responsible to?



The Court of Honour is responsible to the whole Scout troop. It will only be able to make big decisions (such as where to hold summer camp), if it has proved that it can make sensible small decisions. It's impossible for every troop member to be involved directly with all decisions. Patrol leaders, therefore, have the very important task of representing the ideas of all patrol members, and not just their own views.

Hints for Starters

Write down a list of the main items which you must discuss at your next patrol meeting. Then, at the meeting, write down the opinions of your patrol on the same sheet of paper so it's ready to take back to the next Court of Honour.

Remember: your Scouter is responsible for the overall safety and welfare of the Scouts. Your leader, even when not attending your meetings, still has the final say regarding whether an activity can take place or not. Something which you are planning may be against Scouts Canada's rules, or simply too dangerous. If you invite your Scouter to the Court of Honour, it may save a lot of time. The Court of Honour should always inform the whole troop and its leaders of decisions it makes.

Hints for Starters

Perhaps you have patrol leaders who are good at writing or art. They could produce a troop newsletter to help communicate the Court of Honour's decisions. They might even want to put together a poster for display on a troop notice board.

What's in it for me?



Can the Court of Honour do anything just for itself?



You can really influence what happens in your troop, help to arrange the kind of activities you and your friends want to experience, and make sure your Scouting is full of fun, adventure and challenge. You'll also be gaining new skills which will help you with your awards, and be useful outside Scouting (see Chapter 8).

Yes. While its main job is to look after and represent the interests of all Scouts in the troop, it can organize a few special events just for patrol leaders and other older Scouts. These might include a special activity camp, a Christmas dinner or special expeditions that work towards the Chief Scout's Award.

Hints for Starters

Why not organize a weekend just for Court of Honour members? You could enjoy special activities, while also setting aside plenty of time to complete Court of Honour work.

Being part of the Court of Honour will eat up quite a lot of time as a patrol leader. But if your troop is going to experience the activities it wants to, you and your fellow patrol leaders must take responsibility and *make it happen*. So, grasp the challenge and go for it!

NOTES

Chapter 5

Getting the Job Done!

Helping Your Patrol Learn

One of your jobs involves making sure that Scouts in your patrol progress through the award scheme and gain badges while having fun and taking part in lots of different activities. How can you get started?

Decide What Needs Doing

The first step involves discussing with your patrol an activity that they really want to do. Learning for learning's sake is often boring, but learning because it will let you do something exciting is worthwhile.



Agree on an Activity

Once you've agreed on an idea, you'll have to find out what skills your patrol needs to do the activity in an enjoyable way, while making progress in Scouting.

These skills might be practical ones, such as first aid, tent pitching or fire lighting. Your Scouts will have to learn what map symbols mean, or what foods help make a balanced menu.

Alternatively, the skills might involve learning how to work as a team, or how to ask someone formally to help with an activity.

Idea — Let's go on a night hike.

Check these details: Are patrol members used to hiking? Do they know how to use a compass and plan routes using maps? Do they



know what equipment to take and how to use it? Are they all familiar with safety precautions?

At a patrol meeting, chat with members about what they already know. Check your patrol's records to see how learning these skills and doing the activity will help each person advance in the award scheme. Your Scouter will be able to help you keep track of this. List what tasks need to be done. If you're stuck for an idea or one member needs to do something special to finish an award, you might look at the records first.

Planning

Now that you have an idea who needs to learn what, it's time to start planning how to train your patrol. As the patrol leader you may wish to do some of this training but it doesn't always have to be you. If you don't know what you're talking about, don't lead any sessions. No one is asking you to be an expert at everything. Besides, others in your patrol or troop may have mastered a particular skill better than you. If this is the case, use them to help you with the training. Ask yourself:

- What exactly will we do?
- When?
- For how long?
- Who will do the training or help with the training?
- What equipment will we need?

When deciding these details, it's worth thinking about how people learn.

How People Learn

People learn skills in many different ways:

By listening...

This can be boring but is sometimes necessary.

By watching...

Use visual aids such as video, posters, overhead projectors or slides to make this more interesting.

By copying...

This is a very effective learning method, but remember that your mistakes will be copied as well!

By doing...

This is by far the most effective way to learn.

It's often said,

“What I hear I forget,
What I see I remember,
What I do I know.”

A mixture of these methods is usually best, but *always make it fun*. If the training is part of a game or activity, it's more interesting, too.

Models, games and charts are great training aids. These will both keep attention and make the learning easier. Here's an even better idea. Get your Scouts to make their own training aids: listening, watching and doing. They will learn by mak-

ing them, and they can use them later to train other Scouts.

Putting Training into Practice

Having decided which skill you're going to concentrate on, how should you organize the training? Your time would be best spent in the following way:

10% on explanation,
25% on demonstration,
65% on practice.

Don't expect everyone to learn immediately, or at the same speed. Plan your training on several occasions so your patrol members become more confident.

Try to vary the way you deal with topics. How? Pitch a tent blind-folded, try tying knots using one hand only, and so on.

Help each person until he or she can do the activity alone. Get the Scout to practise with, or to teach, someone else.

Put your training into a different activity. It could be part of an incident hike around the headquarters or a patrol challenge. Making a game out of the training might help give Scouts the motivation to learn.

Scouts isn't school, so don't be bossy! Be a helper. Praise someone who does things right. Give lots of encouragement. Make allowances



for individual members of your patrol, but don't be happy with anyone's second best — especially your own.

Remember: not everyone is as strong and quick as everyone else. Make allowances for those with special needs or those who have never done the activity before. They may just need more time to practise, or a little longer to understand.

Looking Back (Evaluating)

At some time you will have to consider how well your patrol has learned the skill or activity that you've been passing on. This is called *evaluating*.

Evaluating is a way of identifying what went well, what was learned, and what could be improved next time, or need additional attention. Probably, you'll have a rough idea yourself how things went, but to

get the most from the evaluation you'll need to consult your patrol.

Ask them:

- Was it fun?
- Did anyone make progress?
- Did they learn the skill by doing the activities?
- Could the Scouts do it on their own next time?
- Do we want to do another activity using these skills?

Take the previous example of the night hike. If, for example, you have now done some training activities using map and compass, equipment and safety, the best way to evaluate this training is to plan a night hike. Let others lead it, and see how they do using the skills they've learned.



A training cycle

1. Agree on an activity (don't forget to consult your patrol).
2. Plan...
 - Who will do it?
 - When?
 - How long will it last?
 - What preparation is needed?
 - Which method?
3. Do the training activities.
4. Look back (evaluate).

Example Training Plans

Cooking on an open fire — Voyageur Award — Outdoor Skills

#12 Demonstrate the ability to lay, light, and safely extinguish a fire leaving no trace.

#13 Cook a simple outdoor meal.

Session 1

10 minutes

Show how to lay a fire. Point out the different sizes of wood from kindling through to larger burning pieces. Tell them that just piling wood up will make lighting the fire difficult.

20 minutes

Split the patrol up into groups of two or three. Each group collects wood and builds a fire.

30 minutes

Light fires and cook sausages on sticks. Put out fires and clear away.

Session 2

10 minutes

Remind the patrol about laying fires correctly. Show how to protect cooking pots from smoke by spreading dish soap over the outer surface. Mention the importance of using lids to keep contents clean.

20 minutes

Run a competition between working groups to see who can be first to get a litre of water to boil on an open fire.

30 minutes

Using the boiling water, divide it up into several pots to test out some of the dehydrated foods which you can buy for lightweight expeditions. Each Scout should rate the finished dishes on a scale of one to ten.

Think of favourite foods which could be cooked on an open fire. Make a wall chart. From the suggestions decide upon a menu for a full meal.

Session 3

Invite a guest, such as your district commissioner or Scouter, to a meal. The patrol has to work together to cook the meal which was planned last session. Present the meal in style with candlesticks on the table and full waiter service. Different members of the patrol could take responsibility for different meal courses.

Navigation — Voyager Award — outdoor skills

#9 *Demonstrate your knowledge of maps and compasses. (#1 and #3)*

Session 1

10 minutes

Check that everyone knows the sixteen points of the compass.





Patrol game

Draw circles on the floor. Each patrol member stands in a circle blindfolded. The patrol leader makes sure everyone is standing facing in the same direction, which is then called "North."

The patrol leader calls out directions and number of paces. The Scouts have to turn to the correct direction and walk the right number of paces. Give about six directions so they bring the Scout back to the circle again if performed properly. The Scouts take off their blindfolds to see how close they are to their starting positions.

10 minutes

Demonstrate the use of a compass. Each Scout needs a compass to practise with. Call out a bearing, and your Scouts have to point in the right direction.

30 minutes

Scouts make their own large training compass from cardboard. (Test each Scout individually as the compass is being made.)

Session 2

10 minutes

Review the compass with the patrol.

30 minutes

Patrol game — find your bearings

In this game you'll be creating words using compass bearings. Each Scout should have a pencil, paper and compass. Mark out a circle in a field and place stakes in the ground with a single, highly visible letter on each stake.

Each Scout (or team) must spell out a word by finding its compass

headings. (See diagram.) For example, if assigned the word "SYMBOL", a Scout would take a compass reading to the first letter ("S") from the centre stake. After marking the bearing down, the Scout would walk to the "S" and take a bearing to the next letter ("Y") and continue until finishing the word. Patrol leaders must check to make sure the bearings are correct. Depending on the size of the circle, you could have groups of Scouts all playing at once.

Session 3

Set up an orienteering course. Each Scout is timed round the course and has to collect a letter or symbol at each base. Make the course about six bases long. The Scouts set off on the course at five minute intervals. Have a prize for the quickest and most accurate Scout.

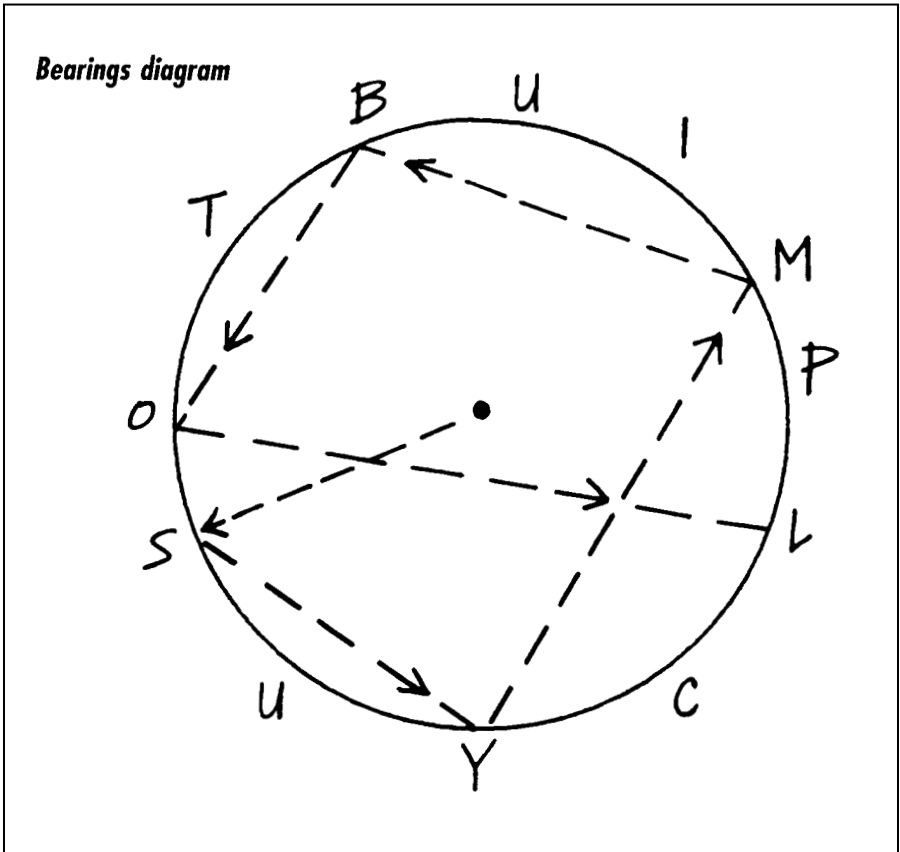

Chapter 6

Patrol Activities

The Court of Honour and your patrol meetings will begin to produce ideas for future meetings. Your Scouts need to convert these into action, otherwise those who suggest them will be disappointed.

Some ideas will be easy to implement (such as going swimming), while others will involve more preparation.

- Going on a night hike involves sorting out a route, transportation, checking it with your

Scouter, and making arrangements with parents.

- Teaching first aid might involve calling in an expert to help you, and getting equipment together.
- Raising money is a good idea, but how are you going to do it?

Carefully plan and think through all activities you do as a patrol.

Choosing Activities

Can the activity involve everyone?



Every one of us is different, and we all like doing some things more than others. This is, of course, true of patrols as well. Activities that

you choose will have to be ones that *most* of you want. To be fair, ensure that over time, the patrol tries out each person's favourite activity.

Sometimes, Scouts may have physical or medical conditions which may limit their abilities to take part in activities. These Scouts are still part of your patrol, and their wishes, ideas and expectations should be given as much weight or value as those of other members. Leaders may be able to provide support in these circumstances.

Occasionally patrol members may not want to do an activity, or feel that they can't for some reason. Is that okay? Sure! Scouting is for fun. No one should be **made** to do anything. Do talk to the Scout, though. You may be able to overcome the person's reluctance, or the Scout may be just a little nervous.

Try to involve the Scout somehow. For example, could the person organize the activity or lead it without doing it? On troop nights, choose activities that everyone enjoys.

Safety



Is the activity sensible and safe?



When you're thinking of ideas, some silly or dangerous ones always come up. You need to explain immediately why they're not suitable. As a patrol, though, there's no reason why you shouldn't do adventurous activities, as long as they're properly run. Most adventurous activities have special rules. Your Scouter will be able to tell you about them, and probably find some specialist to help with the activity.

Safety is also a chief concern for more everyday activities. In fact, most accidents happen during ordinary games and activities (things like stove burns or accidents when using sports equipment).

Think **safety first**, whatever the activity.

Permission



Before you finally agree on an idea with your patrol, check it out. This is where your Scouter comes in. Whatever you're planning, no matter how simple it may sound, check it out with your leader first. Your leader will be able to help you with the correct contacts, check what Scout rules apply, and what training (if any) you'll need. Your Scouter will also advise you on safety.

It's important to realize that even though you'll run the activity, your Scouter has overall responsibility to your parents for what you do. Keep leaders informed about your plans. You must listen to advice, even if it appears to spoil your plans.

You'll also need to make sure the parents of patrol members approve, as well as possibly other people, such as camp chiefs or quartermasters.

Equipment

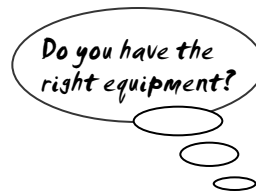

Most activities depend on having the correct equipment. Climbers need good quality ropes and slings; canoeists need PFDs or life jackets and safety-tested boats; cyclists need helmets, and so on. Faulty or old equipment can be very dangerous. Don't take the risk.

You can often rent or borrow good equipment for adventurous activities. Outfitters may also offer trained instructors.

Check all your equipment before the activity. Make sure it's complete and not damaged in any way. If it is, replace the damaged item before setting out. **Never take unnecessary chances.** If you borrow or rent equipment, of course, it's your responsibility to look after it. Take good care of it. If something breaks — accidents do happen — then report it as soon as you get back. Make sure no one uses the equipment until it is repaired.

In short, activities can be quiet, noisy, helpful, useful, long, short. They can take place on legs, on bikes, in canoes, in the air. They can use footballs, baseballs, pioneering poles, computers, guitars. They may be cheap, expensive, clean or scruffy. But above all, activities must have a point to them, and *they must be fun!*

Here's an activity checklist.

- Can it involve everyone?
- Is the activity sensible and safe?
- Have you checked with leaders and parents?
- Do you have the right equipment?

Ideas

So what do you do and when? There are thousands of different things which you can do with your patrol, either on troop night, patrol night, during short camps and long camps, in the evenings and, of



course, on weekends. The list is as long as your imagination!

Patrol exchange

Swap with a patrol from another troop, and “sample” each other’s troop meeting.

Joint meetings

Meet with another troop, a Venturer company, or your local Girl Guides.

Guest night

Invite some friends from school or from the local youth club to spend the evening or weekend “Scouting.” Here is your chance to show them what you do.

Game show

Copy an idea from television and run your own game show challenge.

Wacky fundraising

Raise money with a sponsored sand castle building project, or an all-night table tennis marathon.

First aid night

Set up a “nasty accident” and demonstrate how you would handle the emergency. This offers a good chance for making simulated blood and wounds, and plenty of playacting for a serious purpose.

Challenge badge evening or weekend

Take the patrol through the requirements of a challenge badge. This is a good chance to choose one of the more unusual badges, and to call in some expert help.

“Make a meal of it” night

A helpful parent could open her kitchen at home to your patrol, and involve everyone in making a meal, which could be as simple or as elaborate as you wish.

Patrol goes to town

Visit the ice rink, theatre, cinema, bowling alley, a rock concert, fair ground, swimming pool, pizza parlour.

Special visit

Go to your town hall, television studios, radio stations, hospital children’s unit, power station, newspaper office, mosque, ship-



yard, sewage works, ferry terminal, telephone exchange, clothing factory, engineering works, sports centre.

If you put your mind to it, you’ll find all sorts of people who can help to arrange an interesting visit: parents, friends, parents of friends, friends of parents, your leaders, other leaders, neighbours, tourist information centres. Ask these people politely and you may be lucky.

Craft night

Make something useful or attractive from a material of your choice: leather, wood, plaster, paper, glass. You may want to bring in an expert to help.

Photography

Take some interesting shots either in colour or black and white, and organize an exhibit at your meeting hall, the local library or shopping mall. The beauty of using black and white film is that you can develop, print, and enlarge your own photographs much more easily than you can with colour film.

“Learn a new skill” night

People have a lot of different hobbies. Members of the patrol and their friends will have plenty of interests which they will be willing to share.

Information technology

Lots of people have access to a personal computer. Spend an evening sharing new games or developing skills such as program writing, desktop publishing, spread sheets, or graphic art programs.

Video project

Write, plan, shoot, edit and dub a short video about something that interests you. Lots of people have camcorders. Call around and you'll probably be able to borrow one.

Adventurous Activities

Adventure activities offer more scope as long as they are:

- well prepared,
- authorised by your leader,
- safe.

Adventure activities could involve a half day, a whole day, a weekend, or a series of weekends. Again, the list is endless. Use the opportunities that present themselves most readily.





Some ready-to-use ideas...

Activity alphabet:

- | | | |
|-------------------------|--------------------|---------------------------|
| A Archery | K Kite making | U Underground exploration |
| B Ballista construction | L Lacrosse | V Vehicle maintenance |
| C Candle cooking | M Model railways | W Windsurfing |
| D Dry slope skiing | N Night hike | X Xerographic art |
| E Enamelaire | O Orienteering | Y Yachting |
| F Forestry | P Panning for gold | Z Zoo visit |
| G Glass Blowing | Q Quizzes | |
| H Horse Riding | R Rafting | |
| I Igloo construction | S Snorkelling | |
| J Joke night | T Trampoline night | |

More Ready-to-Use Ideas

What's wrong? Stuck for an idea? Well here are a few activities you might try.

Things to make

Spit oven

Equipment:

- 3 large size juice cans
(all the same size with labels removed)
- Bannock mixture
- Firewood
- Matches
- Long "green" stick
- Can opener

Using the can opener, cut the tops out of two of the cans. Now, put a hole in the bottoms large enough to thread the "green stick" through. (Cans #1 and #2) Cut the top and bottom out of the third can. (Can #3) Make the bannock mixture, and wind it around the "green" stick.



Assemble the oven by sliding can #3 over the stick, then slide cans #1 and #2 on either end. Telescope them together, poking the green stick through the holes.

Support the oven over the fire; turn it around occasionally to get even cooking.

What else could you cook in this oven? Could you cook a whole meal?

Basic bannock bread

Ingredients:

- 1 cup flour
- 1 tbsp baking powder
- 1/2 tsp salt
- water

Mix dry ingredients with a few tablespoons of water. Bake 20-30 minutes in a covered oven. Bake the dough either as one large loaf or in pieces twisted around a stick, and cooked over coals. Serves 3-4.

Camp stool

Equipment:

- 3-300 mm × 300 mm squares of 10 mm plywood
- 4-305 mm long strips of 10 mm × 10 mm softwood
- Saw
- Hammer
- Nails or glue

Make the legs by cutting two pieces to the shapes as shown.

Edge the third piece with the softwood, and glue and nail in place.

If you want a permanent stool, just nail and glue the top piece together.

If your balance is good, leave the top piece separate so you can pack your stool flat for travelling to and from camp.

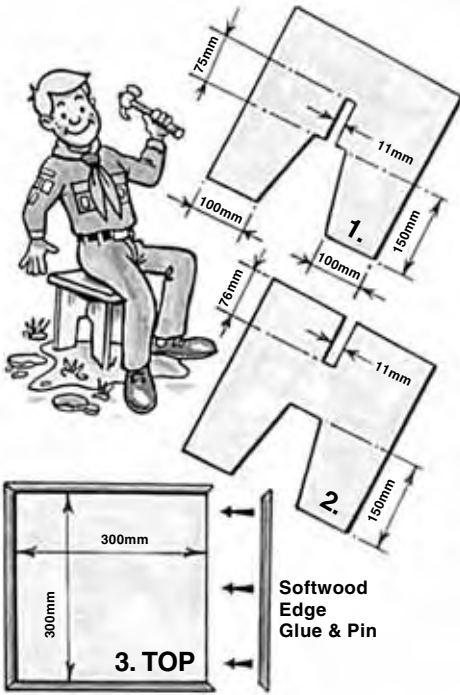

Rockets

Equipment:

- Plastic bottle (i.e. 2 litre pop bottle)
- Cork to fit the bottle
- Plastic tube
- Foot pump
- Old wood and hinge to make a launch pad
- Nails and screws

Cut the cork to fit the neck of the plastic bottle tightly. Hollow through the middle of the cork so the plastic tube just fits through. For a few dollars, you can buy (from a shop selling wine-making supplies) a cork sized correctly with the middle hole already drilled out.

Make the launcher from wood with side rails to stop the rocket from leaping off sideways. Put a hinge on it so you can change the angle of the launcher. (See picture below.)

To launch the rocket, place a small amount of water in the bottle and push the cork firmly into its neck. Place the rocket on the launcher and then use the pump to build up pressure inside the bottle. When enough pressure has built up, the rocket will shoot off. Make sure the area in front of the launcher is clear of people before you launch! *Never shoot it at someone.*



You could use cardboard and tape to make directional fins. Test your rockets for height, accuracy, flight path. Can you make them turn corners?

Let's make a sleigh

Here's a way to carry some of the gear to your next winter camp. It makes a great fall patrol project.

Equipment:

- 12 m of 1×2 clear pine
- .25 kg of 1 1/2" dry wall screws
- Drill and bit
- Saw
- Rope

Cut the wood in the dimensions shown by the diagram. Soak the

wood in boiling water for at least two hours before you try to bend it. While the plan shows how you can make your own runners, an old pair of skis will do the trick as well. When you're finished building the sleigh, paint it in troop or patrol colours.

Run a saw cut for 35 cm through thickness of the ski. Use a piece of veneer or plywood and glue in place. Form bend. This method requires no soaking.

Drill hole and fasten tow rope on bottom.

Drill and countersink all screws.

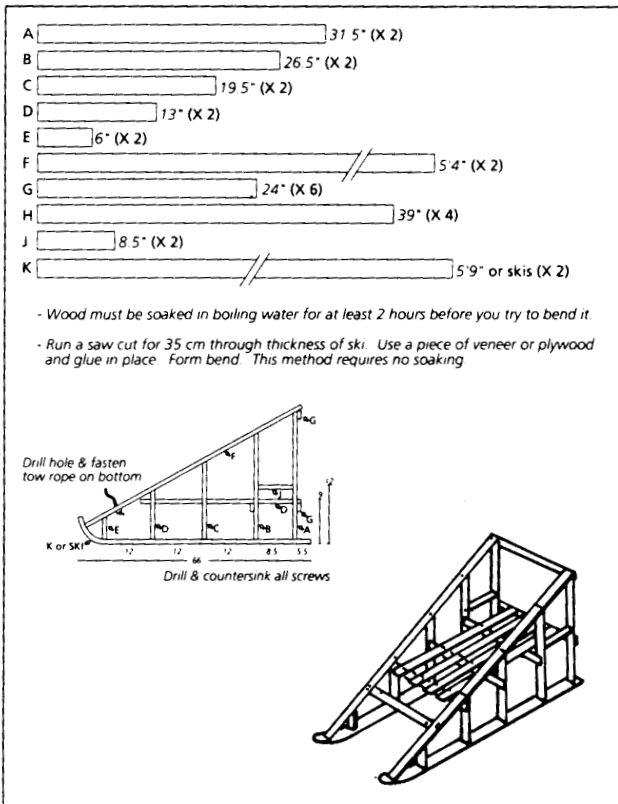

Woggles

You can design and make your own special patrol woggle out of almost anything (for example, hollowed out meat bones or pieces of softwood). You may want to carve and decorate the outside of your woggles.

To make plaited woggles, just cut strips of leather from old handbags

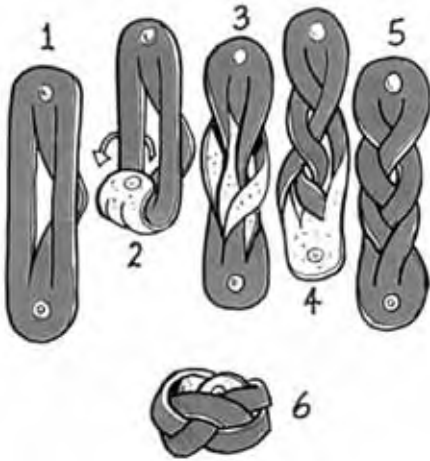

(perhaps one left from a yard sale). Make two short cuts in the leather, then plait them together. The two ends can then be glued or tied together.

Make your own energy bars

Here's a trail food you can make for your next hike or canoe trip.

Ingredients:

Raisins, dates, figs, coconut, prunes, pecans, walnuts and hazelnuts.

Mix the ingredients together in equal portions. Put your mixture through a food chopper or blender, or chop finely with a sharp knife. Pack tightly into bars on waxed paper and wrap in foil. It may be easier to cover a cookie sheet with waxed paper, pack down the mixture until it's 6–12 mm thick, cut into bars and wrap in waxed paper and foil.



Emergency rations

It's always a good idea to have high energy food with you for an emergency.

Ingredients:

- 3 cups of rolled oats
- 2½ cups powdered milk
- ½ package lemon or orange flavoured gelatin
- 1 cup sugar
- 2 tbsp honey
- 3 tbsp water

Place rolled oats, powdered milk and sugar in a bowl. Add water to honey and bring to a boil. Dissolve gelatin in honey-water mixture and add to dry ingredients. After mixing well, add additional water a teaspoon at a time until the mixture is barely moist enough to be molded. Shape into two bars.

Dry the bars in the oven under low heat, wrap in foil, and place them in a covered container for indefinite storage.

Each bar contains enough food for one day. You can eat the bar dry or cook it in about a pint of water.

Cook an egg in an orange

Here's a way to cook without dirtying a frying pan. Cut the bottom one quarter off an orange. Carefully spoon out the inside of the orange, eating as you go. Break an egg into your orange cup and set on the grill for cooking.

Hanging boiled eggs

Ingredients:

- 1 raw egg
- Sewing needle
- Strong cotton sewing thread
- Fire materials

Thread the needle with the cotton thread. Then, *being extremely careful*, at the narrowest end of the egg about one centimetre down from the top, push the needle through the egg and out the other side. Pull through about 50 cm of thread, and tie it in a loop. Hang the egg above the embers of the fire — not the flames, or the thread will burn through. The egg will cook inside the shell.

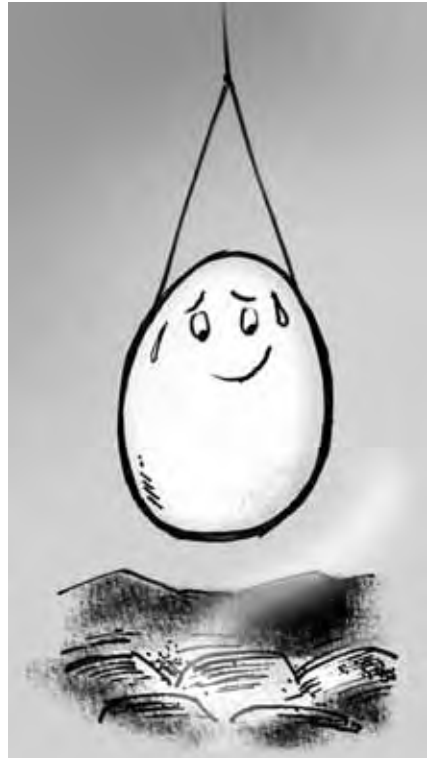

Bacon and egg in a paper bag

Ingredients:

- 1 slice of bacon and 1 egg
- 2 small brown paper bags
- String
- Fire building materials

Optional extras:

- A little milk
- Margarine and salt to taste

Cut the bacon into small pieces and mix together with the beaten egg. Put one paper bag inside the other, then pour the mixture into the bag. Tie the neck of the bag up with the string so you can hang it safely *above the fire's embers*.

When the bottom of the paper bags are soaked through with the egg mixture, hang the bag over the fire and the egg and bacon will cook inside the bag.

If you prefer, add a little milk and margarine when making the mix-

ture. This will produce a scrambled egg rather than an omelette type of flavour. Add salt to taste.

Just for Fun

Air display

Equipment:

- Scrap paper
- Tape

Give each patrol member a set amount of paper, and then challenge the Scouts to make one, or all, of the following which must

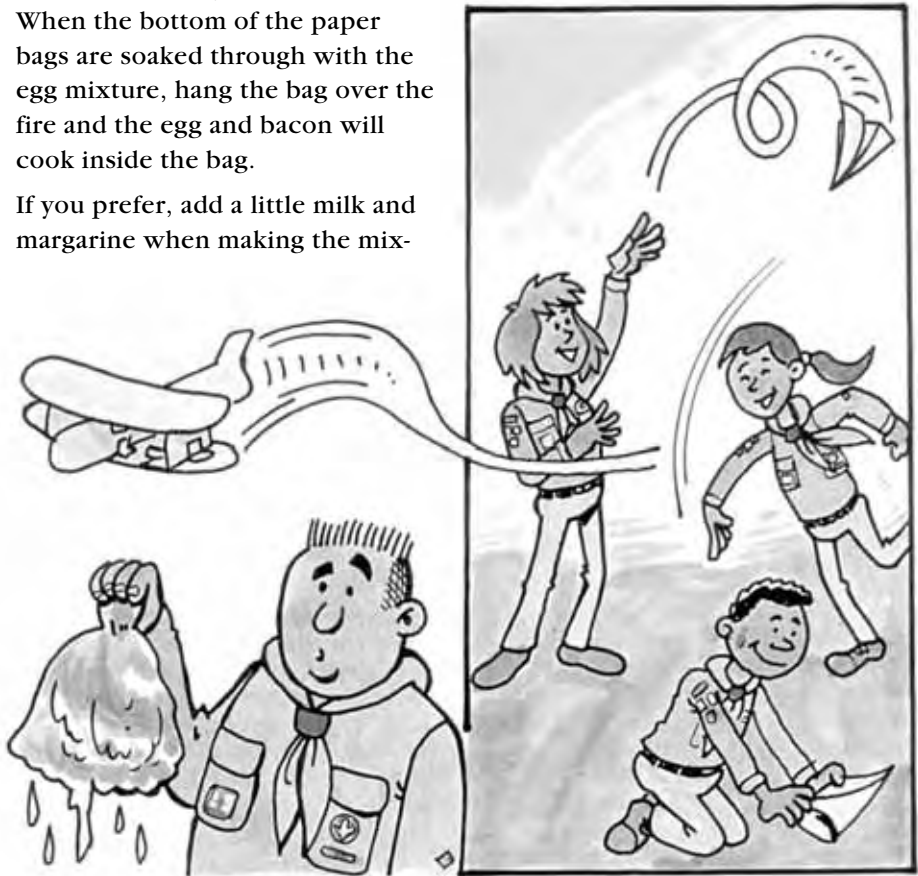

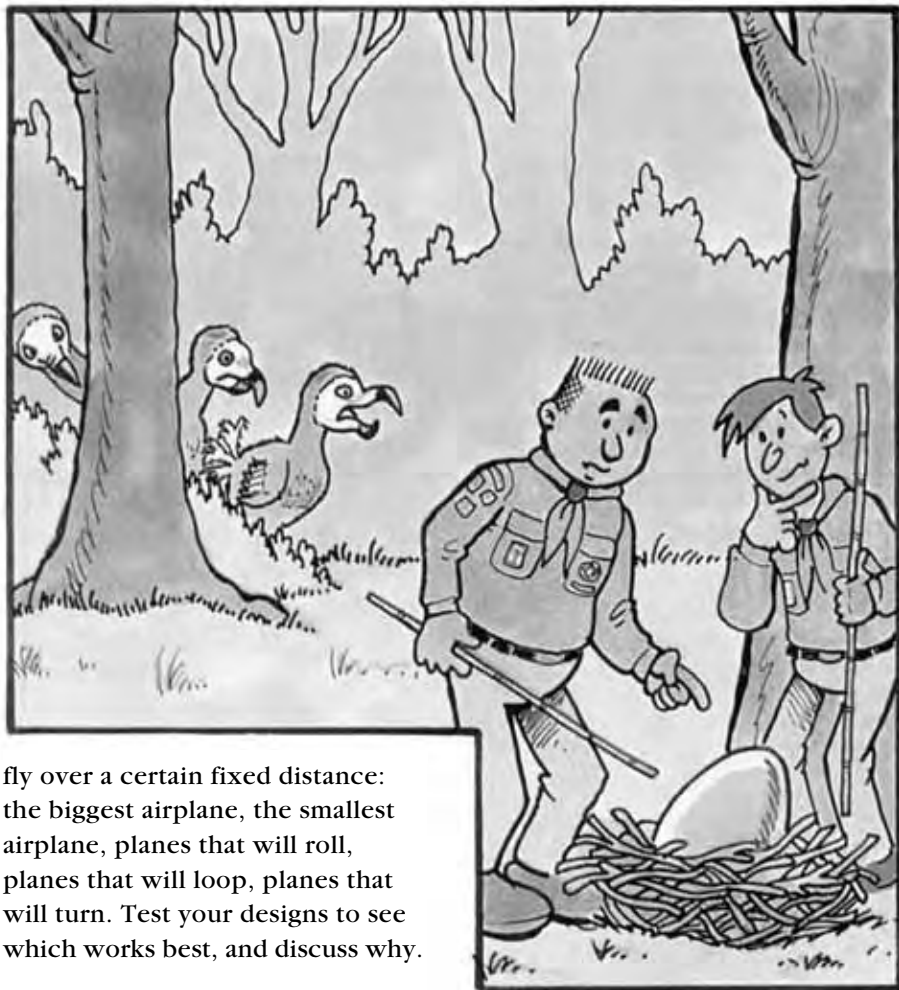

fly over a certain fixed distance: the biggest airplane, the smallest airplane, planes that will roll, planes that will loop, planes that will turn. Test your designs to see which works best, and discuss why.

Remote knotting

Stake out a three-metre radius circle around a tree for each patrol, and give them a 15-metre rope. Two Scouts from each patrol must hold the rope at each end. Without letting go, and without entering the circle, each pair must tie a clove hitch around their tree. Outside the circle, the other patrol members can give advice and raise the rope if necessary. The fastest patrol wins!

The last dodo egg

Equipment:

Small football

2 or 3 staves or bamboo canes

Tell the patrol that the very last dodo egg in the world has been found (the football). No human hands must touch it, or it will break. In pairs, challenge them to move the “egg” from point A to point B using only staves or canes. This

could be around the room, around an obstacle course, around the campsite, or whatever. Count the number of times the Scouts drop the egg.

To make it more exciting (and if you don't mind cleaning up), use a real egg in either an unbreakable bowl or on a plate.

Blindfold pictures

Equipment:

- A large sheet of drawing paper
- Coloured pens
- Pictures from magazines
- Blindfolds

As a patrol, select a picture with a lot of detail from a magazine or book. Study the picture together for about five minutes pointing out specific details to each other:



how many chairs, windows, boats, people, what time does the clock say, etc. Now, blindfold everyone, and working together, reproduce the picture as best you can.

Having tried it once, work out a few simple systems of how you could accomplish the task better.

Active newsletter

Equipment:

- Tape recorder and cassette, or video recorder and cassette, or nothing at all!

Parents and kids are bombarded with lots of junk mail that no one reads. The next time you need to pass on some important information, or get something done (e.g. permission to go on a patrol camp, or expedition, or activity), why not use an active newsletter?

You could use two methods. (1) Write a script containing the information, and then record it on a



tape recorder (being as enthusiastic as possible). Now play it to parents. **OR** (2) If you can borrow a camcorder, record the message on video, or even write a short playlet of a conversation between a Scout and a Scouter. Now act it out for each parent.

What Other Ideas Can You Think Up?



These are just a few ideas and activities you might try. Can your Scouts think up any variations to them? What other ideas can you try? What else could you cook? What else could you do?

Chapter 7

Camping

Why camp as a patrol?



Young people join Scouting to go camping. That's what many surveys tell us. In other words, young people want to go camping!

It's important for the development of your patrol that you spend time together. This will help you get to know each other, as well as give opportunities to help each other, and work as a team. A weekend will give you much more time to

spend together than a regular troop night.

A good patrol camp will help you put your Scouting into practice. It takes you out of the meeting hall and makes all the training worthwhile.

Types of Patrol Camp

The patrol standing camp

A standing camp is one where you spend the whole time at one place. Depending on the site which you choose, this type of camp can give the opportunity to do all sorts of activities, provided both by the site and by yourselves.

This would be the best type of camp for a new patrol.



Recommended experience for the patrol leader:

You should have experience in basic camp skills, tents, fires, stoves, camp cooking. You should also have spent at least five nights on previous weekends or troop camps. This will give you background knowledge to make sure that your patrol camp is properly run.

Your Scouter will ensure that you have had enough experience to lead a camp. He or she will also help you out.

As patrols at a troop standing camp

You can camp as a patrol, even if all the troop is together. At this

camp, each patrol is responsible for its own program, menu and equipment, but all patrols camp on the same site at the same time. They're separated only for privacy. Your Scouters can then easily check on how things are going, and offer advice. This type of camp is particularly suitable for a patrol leader who is taking Scouts camping for the first time.

Recommended experience for the patrol leader:

Some camping experience as a Scout.

Indoor camp

Many Scout campsites offer huts. These can be a fun way to spend a weekend. What are the advantages? You can camp during cold



winter months and don't need to take much equipment. You'll have to be sure to look after the accommodation and leave it clean and tidy for the next group to use.

At home camp

If your sponsor has a building, why not hold a patrol overnight event there, either camping or staying inside. Perhaps you could use it as a practice for a full patrol camp so the Scouts can get used to cooking for themselves. Alternatively, other groups in your district might let you use their buildings.

Recommended experience for the patrol leader:

This is a good type of camp for a patrol leader with little or no camping experience.

Take a hike!

Why not consider a patrol weekend hike? This is a different type of camping experience; use lightweight tents and perhaps dehydrated foods.

Base your activities on what you can see, do and visit along the way. It's not the ideal camp for first time





campers, but this type of event can help you gain awards or badges.

Recommended experience for the patrol leader:

You should have previous lightweight camping and hiking experience for this type of camping, along with sound knowledge of how to use a map and compass. Most of your patrol will also need to have had some camping and hiking experience.

This type of camp takes a lot more detailed planning. You'll need to provide detailed route plans as well as contact points along the way. The sort of area you choose

to walk in will also make a difference.

District and region camps

Many districts and regions offer opportunities to camp with other Scouts. Often, the patrols are left to make their own arrangements for catering and sleeping while the camp organizers run the program. Activities at this sort of event can be more unusual; you can also easily join in the Scouting spirit on a larger scale. Look for opportunities to join provincial or national camps, too. There are always several provincial camps running each year.

Recommended experience for the patrol leader:

The patrol leader should have run at least one patrol camp successfully.

Special camps and expeditions

What about trying a patrol expedition by cycle or on horseback? Don't forget that it's not just Sea Scouts who can have patrols sailing and canoeing. Naturally, an expedition like this can also involve camping.

Recommended experience for the patrol leader:

The patrol needs to have some experience in the means for travel they choose.

Organizing a Camp

How do you and your patrol actually get a camp or expedition started? How do you plan it?

- Hold a patrol meeting.
- Take your idea to your Scouter.

- Find out what sort of camps you might be allowed to do.
- Agree on the following with your patrol:
 - Who wants to go?
 - Where are you going?
 - How long is the event going to last?
 - When are you going?
 - How much are you willing to pay?
 - What equipment will you need?
- Take your outline idea to your Court of Honour.

It's a good idea to get your Scouter's permission now so your patrol isn't disappointed if things need to be altered. Then, plan in more detail.

You'll want to make firmer plans before you approach parents or guardians. You'll get a much better reaction if you present a well thought out plan with all the relevant details which have your Scouter support.

Either do these tasks yourself or, better yet, delegate them to patrol members, and help them do them.

- Check that the campsite or venue is available.
- Work out a camp program.



- Work out a menu which fits your program.
- Check equipment.
- Arrange transport.
- Work out the cost of the camp.

At each stage, keep your Scouter informed about your plans so he or she can offer advice.

Let's take each of those headings in turn, and look at them in more detail.

The campsite or venue

The type of site you choose to use will affect your overall program. Scouting sites often offer activities such as archery, pioneering or canoeing and can help make your camp action-packed. If you choose a more lonely spot (such as a farm or a field), check to make sure that camping is allowed there. You can't just stick up a tent wherever you like!



When you have chosen your site, visit it to check out the following.

- Is there a convenient water supply?
- Are there toilet and washing facilities?
- What program opportunities does the site offer?
- Can you cook on wood fires or are stoves required?
- How do you get rid of garbage at the site?
- Is there a resident warden or some other adult contact in an emergency?

Camp Programs

Patrol members will have many ideas what they would like to do at camp. Use the facilities and opportunities which the site offers. It's also important to remember that you and your patrol members can all qualify for parts of the award scheme by going on patrol camps. Scouts can earn many challenge badges in part or fully during a weekend camp, including:

- Naturalist
- Pioneering
- Paddling
- Cooking
- Winter Scouting
- World Conservation
- Exploring
- Advanced Camping
- Year Round Camper.

You might want to plan your program around a theme. This will help you think up good ideas; it will give real purpose to your weekend.

Themes	Activities
Survival	Quinzhees Backwoods cooking Navigation Rafting Communication Survival kits
Pioneering	Knots and lashings Splicing Whipping Pioneering project
Conservation	Tree pruning/planting Stream clearing Pitch-in Trail building
Sports	Archery Orienteering Cross-country skiing
Cooking	Backwoods Guest meal Ovens International
Water activities	Canoeing Boating Rafting Sailing Swimming Sailboarding
Hiking	Incident hike Night hike Visit place of interest
Joint Camp	With Venturer company With other troops



Once you've got your ideas together, put them into a structured program for the camp. Here's a suggestion for a weekend with a "survival" theme.

Timetable

Friday

- 6:00 p.m. Arrive at camp, set up site and fence off area.
- 7:30 p.m. Collect wood for campfire.
- 8:30 p.m. Prepare snack.
- 9:00 p.m. Campfire
- 9:30 p.m. Bedtime

Saturday

- 8:00 a.m. Rise, light fire, collect more wood.
- 8:30 a.m. Make breakfast.
- 9:30 a.m. Dishes washed, and site tidied.
- 10:00 a.m. Patrol leader teaches other patrol members various knots and lashing which they'll use later.
- 10:30 a.m. Practise by making camp gadgets for site.
- 11:00 a.m. Look for suitable sites for a watchtower, and set up rope swing.
- 12:00 noon Consider different types of fire on which to cook lunch, and have dinner.
- 1:00 p.m. Have lunch, wash dishes.
- 2:00 p.m. Build a watchtower. Experiment signalling from it.
- 3:30 p.m. Build lean-tos, either individually or in small groups.
- 5:00 p.m. Start preparing backwoods dinner.
- 6:00 p.m. Have dinner.
- 7:00 p.m. Wash dishes and tidy campsite.
- 7:30 p.m. Conservation work or good turn on campsite.
- 8:30 p.m. Campfire and night tracking game.
- 10:00 p.m. Bed (sleeping in lean-tos).

Sunday

- 7:00 a.m. Rise, light fire, have breakfast, wash dishes.
- 8:30 a.m. Dismantle lean-tos and leave site just as you found it.
- 9:00 a.m. Make a rope ladder and use it to climb a tree as a patrol challenge in a set time.
- 11:00 a.m. Dismantle and clear away pioneering projects.
- 12:00 noon Cook lunch and wash dishes.
- 1:00 p.m. After lunch, allow fire to burn out. Flood with water and stir the ashes.
- 1:30 p.m. Take down tents and clear site.
- 2:30 p.m. Litter check around site.
- 3:00 p.m. Depart for home.

Menus

Work out a menu which fits in with your program.

Find out what your patrol likes to eat before planning the menu. If you do this, more people will enjoy the food. List a dozen main meals, and ask patrol members to tick the ones they like. With this methods it's easy to choose the most popular menu.

Use the Canada Food Guide when planning camp menus (see *The Fieldbook for Canadian Scouting*). When camping, you'll be asking your body to do a lot more than usual, so make sure you "fuel up" with the best food. Include the following:

Proteins:

meat, fish, dairy products and vegetables (including baked beans) contain protein.

Carbohydrates:

bread, vegetables, pasta, rice and sugar are sources of carbohydrates.

Fat:

milk, cream, butter, bacon or meat fat are examples of fatty foods. You only need moderate quantities of fats.

Here's a good plan for most campers: start with a good breakfast, a light lunch, a substantial evening meal, and follow it by a hot drink before bed.

Some patrol members might not eat certain foods. So, check while you're planning your menu because:

- some people have allergic or other medical reactions to foods,
- some religions exclude different types of food,
- some people are vegetarians (they don't eat meat or animal products).

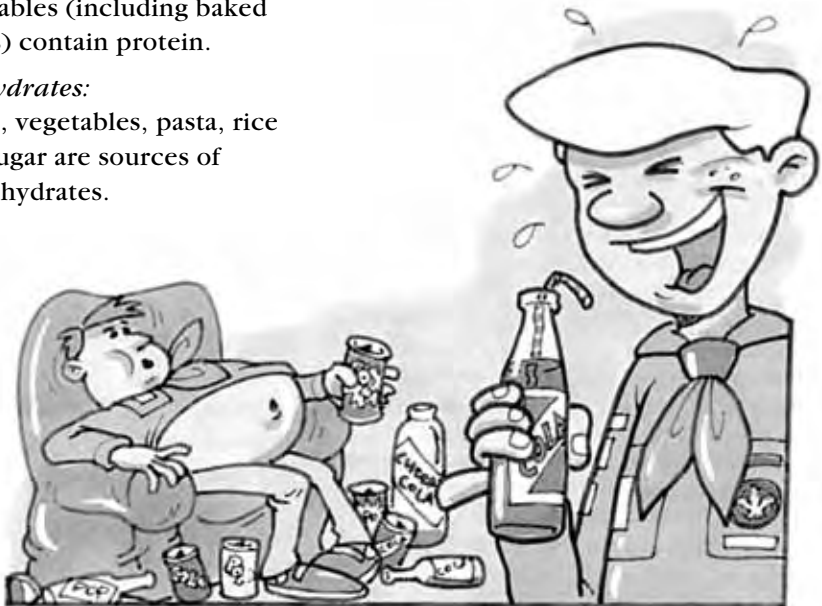

Accept these restrictions or beliefs, and build a menu around them.

It's also important to remember to drink plenty of fluids, particularly if the weather is hot. Water is far better for you than fizzy drinks.

Example weekend menu

Friday

Snack Soup, biscuits

Saturday

Breakfast Cereal
 French toast and syrup
 Toast and jam
 Hot chocolate/milk/
 juice

Lunch Grilled cheese
 sandwiches
 Apple
 Cookies
 Juice/milk

Dinner Spaghetti
 Garlic bread
 Pudding
 Milk

Snack Hot chocolate, biscuits

Sunday

Breakfast Cereal
 Sausages and beans
 Toast and jam
 Hot chocolate/milk/
 juice

Lunch Sandwiches
 Cookies
 Oranges, bananas
 Juice/milk

Be careful to plan your meals around your program. It would be silly to have stew for lunch when you plan to be on a long, exhausting hike!



Equipment

Check equipment

Before setting off, look through all the equipment you're likely to need. It's a good idea to put up tents and dining shelters as a practice exercise on troop night so you can make sure that everything you need is there. Make sure stoves are working, lamps have mantles on, and bottles of gas are full. Check that cooking utensils and pans are clean and in good condition. Don't forget the little things like can openers, potato peelers and toilet paper. Ask yourself: what spares should we bring along?

If your patrol is co-ed, make sure you have separate sleeping tents.

Here's a suggested equipment list for a standing patrol camp. It will vary depending on the length and type of camp. For more information on camping and equipment, check out *The Fieldbook for Canadian Scouting*.

- Sleeping tents
- Ground sheets for tents
- Dining shelter
- Camp table
- One double burner stove and fuel
- One cooler
- A fire grill (if using a fire)
- One hand axe
- One bow saw
- One plastic sheet or old ground sheet

- One lamp
- One frying pan
- One kettle
- Set of pots
- Cooking utensils
- Can opener
- Sharp knife
- Potato peeler
- Water container
- Three dish pans and liquid dish soap
- One scouring pad
- One dish cloth
- Two tea towels
- String and a few clothespegs
- Tin foil
- Plastic garbage bags
- Matches
- Kleenex/toilet paper
- One basic first aid kit
- Activity equipment

As well as the patrol equipment, Scouts will have their own gear to bring. It's a good idea to issue a kit list, particularly to Scouts who may not have camped much before. Here's an example:

- Sleeping bag and blanket
- Personal ground sheet
- Pyjamas
- Camp clothing (shorts, T-shirts, sweatshirts, pants, etc.)
- Warm sweater
- Spare underwear and socks
- Camp footwear for wet and dry weather
- Swim suit and towel
- Wash kit (toothbrush, toothpaste, deodorant, hand soap, face cloth, small towel, comb, etc.)

Transportation

Arrange transportation

Transporting people and equipment can make your camp very expensive. Friendly parents might be willing to take you to your site in cars or vans. Whatever you choose, bear these points in mind.

- Don't overload vehicles with people. Make sure cars and vans are not overcrowded.
- Fasten seatbelts when riding in all vehicles. Never ride in the back of a truck.
- Offer parents some money for gas if they have to travel a long way.
- Everyone should know where they're going to in case one or more vehicles get split up. Drivers should have maps that show the camp.
- Camp equipment is bulky and may be wet or dirty on your return. Be sure to dry it before packing it away.

Cost

Work out the cost of the camp

Managing the finance of a camp can be difficult if you're not used to handling money. Keep track of all income, record all expenditures, and keep receipts.

Split the camp budget into four areas.

1. *Transportation*

Transportation costs will include the cost of getting to and from the site, as well as any trips made during the event.

2. *Food*

Work out a daily rate and multiply it by the number of Scouts going. Parents are usually the best at estimating how much to allow for each day. Or, as an activity, go to a supermarket and find out the cost of your meals.

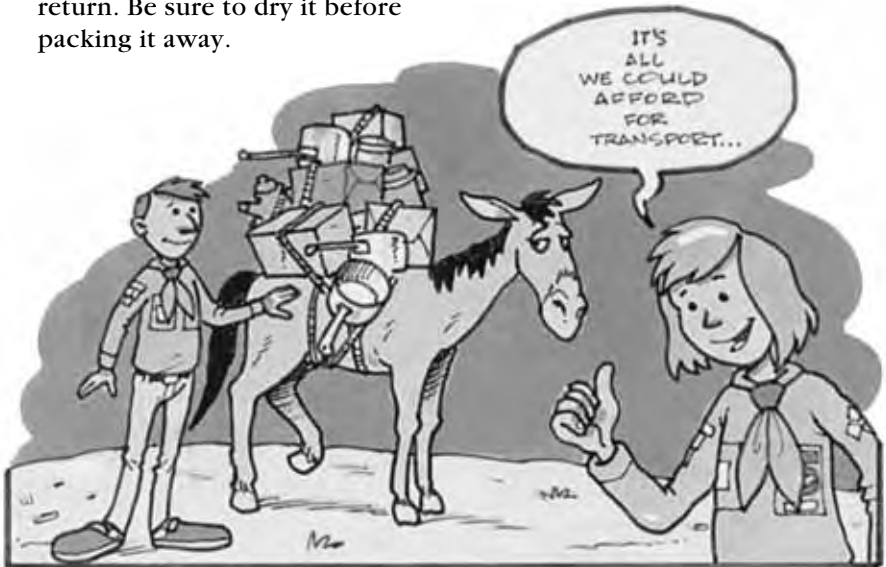



3. *Camp fees*

You may be lucky and find a place where you're not charged for camping, but some Scout sites charge a daily rate per camper. Ask when you write for information.

4. *Activities*

The activity budget is dependent on what you want to do in camp. Ask for any activity charges when you visit the site.

There are at least two proven approaches how to budget for your camp.

Method 1

Decide where you are going, what you're charging for meals and site fees, and what activities you're doing. Add all the costs together, add on 10% in case of unforeseen problems, and divide by the num-

ber of Scouts going. This gives a fee per person.

This method emphasizes what you're going to do, rather than keeping costs down. Make sure patrol members are not discouraged by the final cost of the project.

Method 2

Find out what financial figure will be acceptable to the patrol members. Subtract from this figure the cost of food and site fees, as these are fixed costs. The remaining budget will give you an idea how far you can travel and what activities you can afford.

This method emphasizes keeping costs down. Be careful that the event is worthwhile and exciting enough to make your patrol want to be part of it.

In the end, most budgets involve a compromise between what you would like to do and what is reasonably affordable.

When the camp ends, prepare a simple list showing how much money was received and how much was spent; give this to your Scouter.

Getting Permission

Now that you have developed your plans and things are beginning to come together, it's time to obtain final permission. This needs to come from three sources.

- The Court of Honour.
- Your Scouter.
- The parents/guardians of each Scout attending.

The Court of Honour and Scouter should have been deeply involved in the camp so far anyway, but parents may need to be approached for the first time. Set out the details as well as you can to show what work has gone into the organization. Try to put the plans into a well presented letter so each Scout and parent gets:

- information about the cost, location and duration of the camp,
- travel arrangements (especially if you want help),
- a personal kit list,
- a program outline, including special activities,
- a form for parents to sign giving their permission.



Your Scouter will be able to help you compile or check this information. Why not ask parents to attend a ten-minute meeting after a troop night so you and your leader can explain the project face to face. Let them ask their questions here.

Off to camp... Have a good time!

On Your Return

- Return all equipment in good condition.
- Give “Thank you” notes to all those who helped.
- Your patrol should review the camp and make a few notes so you can repeat the good things in the future, and correct any mistakes.

It’s not easy to organize your own patrol camp; look on it as a project which will take several weeks to complete. It is, however, one of the best things you can do for your patrol. You’ll gain a lot of satisfaction from knowing that you have helped make it all happen.

Remember how we began this chapter? Most Scouts join the Movement to go camping. Don’t disappoint them. The responsibility is yours and the Scouter’s.

Chapter 8

Personal File

Where Next?

This book has dealt with your role as a patrol leader. It's easy to spend all your time helping your patrol do exciting things, and lose track of your own development. This last chapter is, therefore, about YOU as a person and YOUR needs. It's also

about what you can do after leaving the troop.

As a patrol leader, you'll have gained some useful skills that you will use during the rest of your life. Here's a list of personal qualities which would help you in the world of work. Look through them. How do you rate?

	Good	Quite good	Need more help
Working with individuals			
• Do I set a good example?	<input type="checkbox"/>	<input type="checkbox"/>	<input type="checkbox"/>
• Am I able to work with and help others?	<input type="checkbox"/>	<input type="checkbox"/>	<input type="checkbox"/>
• Am I good at listening to other people's ideas?	<input type="checkbox"/>	<input type="checkbox"/>	<input type="checkbox"/>
• Am I able to help people solve problems?	<input type="checkbox"/>	<input type="checkbox"/>	<input type="checkbox"/>
Working with a team			
• Am I fair in the way I deal with others?	<input type="checkbox"/>	<input type="checkbox"/>	<input type="checkbox"/>
• Am I able to lead a team of people?	<input type="checkbox"/>	<input type="checkbox"/>	<input type="checkbox"/>
• Am I able to let someone else take the lead?	<input type="checkbox"/>	<input type="checkbox"/>	<input type="checkbox"/>
• Can I teach a skill to a group of people?	<input type="checkbox"/>	<input type="checkbox"/>	<input type="checkbox"/>
Working with equipment			
• Am I able to organize equipment for a project?	<input type="checkbox"/>	<input type="checkbox"/>	<input type="checkbox"/>
• Can I keep records accurately?	<input type="checkbox"/>	<input type="checkbox"/>	<input type="checkbox"/>
• Do I treat equipment responsibly?	<input type="checkbox"/>	<input type="checkbox"/>	<input type="checkbox"/>
Yourself			
• Can I plan and organize an activity?	<input type="checkbox"/>	<input type="checkbox"/>	<input type="checkbox"/>
• Can I accept responsibility?	<input type="checkbox"/>	<input type="checkbox"/>	<input type="checkbox"/>
• Am I friendly towards others?	<input type="checkbox"/>	<input type="checkbox"/>	<input type="checkbox"/>
• Do I have good self-control?	<input type="checkbox"/>	<input type="checkbox"/>	<input type="checkbox"/>

Using Your Experiences

All these skills and attributes are useful to you — both now and in the future. Employers will look for them. You can highlight some of these in application letters which you send for jobs or university.

Your Progress Within Scouting

It's important that you keep developing your own Scouting interests. You may want to complete the

Chief Scout's Award. Try to keep your needs in mind, as well as the needs of your patrol. Activities organized for older Scouts will help you make progress in the award scheme while your work with the patrol will also count.

Adventurous activities

Regions and districts often have a team of people that specializes in activities such as climbing, caving, sailing, and canoeing. They'll be glad to suggest ways for you to develop interests. Many Venturer companies specialize in certain activities, too.



The Next Scouting Step — Venturers



Venturers has a lot to offer if you get involved. As with Scouts, you play a part in the success of your Venturer company. It'll take a little time to get used to, but remember your first days as a Scout. You were probably a bit scared; you didn't know what to expect; you were no longer "top dog" of the Cub pack.

If you start linking with a Venturer company while you're still a Scout, it will be much easier. You'll know a few faces. Find out how the company is run, what activities they do, and which ones you can take part in.

Training courses

Many regions and districts run leader and "Kim" leadership courses. Why not consider becoming an "activity" leader? Ask your Scouter about these opportunities.

Provincial camps/jamborees

A provincial camp/jamboree is a great experience. Many provinces run provincial camps each year. Perhaps a special patrol made up of older Scouts could attend one. Get information about these from your local Scout Office.

Why not...

- invite the Venturers to give a talk and slide show of Venturer activities?
- attend key meetings and activities over a short period of time?
- invite Venturers to organize and run a patrol activity?
- arrange for your patrol to take part in a Venturer activity?
- have a joint Venturer/Scout meal, possibly on an international theme?
- hold a fundraising project with Venturers?
- organize an environmental project with Venturers?

Venturing offers so many opportunities, you'll not be able to

experience everything. It's worth spending some time choosing the challenges you want, planning how you can do them, and sharing them with your parents, Scouter and others. They may be able to help.

Good luck!

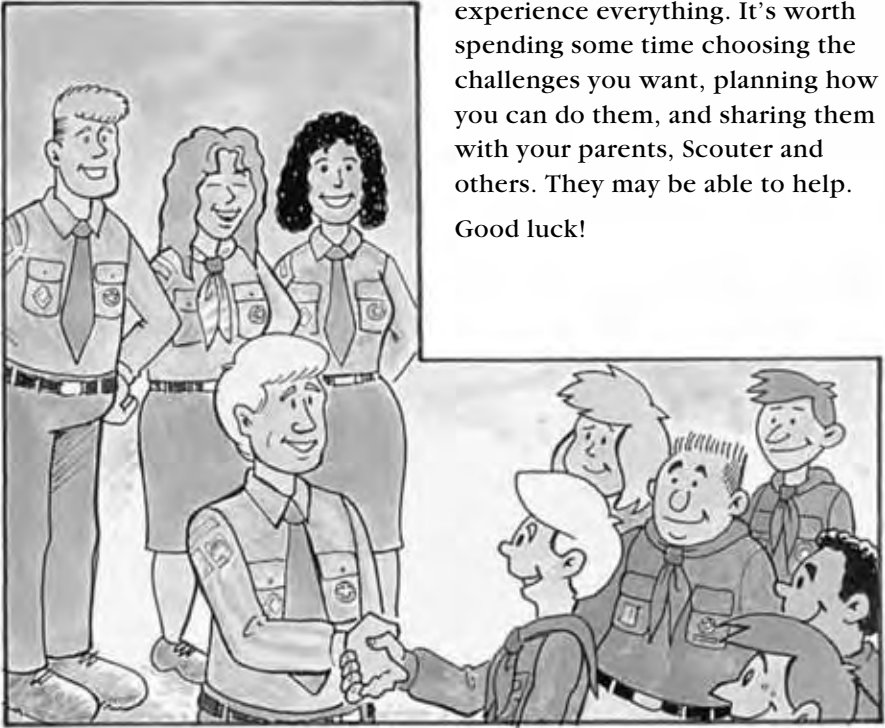



2
trees were saved
for our forests

Preserving our environment

Scouts Canada chose to use recycled paper to print this book and saved these resources¹:

energy	water	greenhouse gases	solid waste
2 million BTUs	3,179 L	92 kg	49 kg

Printed by Webcom Inc.
on Legacy Offset 100% post-consumer waste.



Recycled
Supporting responsible
use of forest resources

Cert no. SW-COC-002358
www.fsc.org
© 1996 Forest Stewardship Council

¹Estimates were made using the Environmental Defense Paper Calculator.



ISBN: 978-1-894187-02-2

